

**FLUKE**®

**Biomedical**

# VT650/VT900A

Gas Flow Analyzer

Users Manual



FBC - 0111

August 2018, Rev. 1

©2018 Fluke Corporation. All rights reserved. All product names are trademarks of their respective companies.

## Warranty and Product Support

Fluke Biomedical warrants this instrument against defects in materials and workmanship for one year from the date of original purchase OR two years if at the end of your first year you send the instrument to a Fluke Biomedical service center for calibration. You will be charged our customary fee for such calibration. During the warranty period, we will repair or at our option replace, at no charge, a product that proves to be defective, provided you return the product, shipping prepaid, to Fluke Biomedical. This warranty covers the original purchaser only and is not transferable. The warranty does not apply if the product has been damaged by accident or misuse or has been serviced or modified by anyone other than an authorized Fluke Biomedical service facility. NO OTHER WARRANTIES, SUCH AS FITNESS FOR A PARTICULAR PURPOSE, ARE EXPRESSED OR IMPLIED. FLUKE SHALL NOT BE LIABLE FOR ANY SPECIAL, INDIRECT, INCIDENTAL OR CONSEQUENTIAL DAMAGES OR LOSSES, INCLUDING LOSS OF DATA, ARISING FROM ANY CAUSE OR THEORY.

This warranty covers only serialized products and their accessory items that bear a distinct serial number tag. Recalibration of instruments is not covered under the warranty.

This warranty gives you specific legal rights and you may also have other rights that vary in different jurisdictions. Since some jurisdictions do not allow the exclusion or limitation of an implied warranty or of incidental or consequential damages, this limitation of liability may not apply to you. If any provision of this warranty is held invalid or unenforceable by a court or other decision-maker of competent jurisdiction, such holding will not affect the validity or enforceability of any other provision.

7/07

# Notices

---

## All Rights Reserved

© Copyright 2018, Fluke Biomedical. No part of this publication may be reproduced, transmitted, transcribed, stored in a retrieval system, or translated into any language without the written permission of Fluke Biomedical.

---

## Copyright Release

Fluke Biomedical agrees to a limited copyright release that allows you to reproduce manuals and other printed materials for use in service training programs and other technical publications. If you would like other reproductions or distributions, submit a written request to Fluke Biomedical.

---

## Unpacking and Inspection

Follow standard receiving practices upon receipt of the instrument. Check the shipping carton for damage. If damage is found, stop unpacking the instrument. Notify the carrier and ask for an agent to be present while the instrument is unpacked. There are no special unpacking instructions, but be careful not to damage the instrument when unpacking it. Inspect the instrument for physical damage such as bent or broken parts, dents, or scratches.

---

## Technical Support

For application support or answers to technical questions, either email [techservices@flukebiomedical.com](mailto:techservices@flukebiomedical.com) or call 1-800- 850-4608 or 1-440-248-9300 (Europe +31-40-2965314).

---

## Claims

Our routine method of shipment is via common carrier, FOB origin. Upon delivery, if physical damage is found, retain all packing materials in their original condition and contact the carrier immediately to file a claim. If the instrument is delivered in good physical condition but does not operate within specifications, or if there are any other problems not caused by shipping damage, please contact Fluke Biomedical or your local sales representative.

---

## Returns and Repairs

### Return Procedure

All items being returned (including all warranty-claim shipments) must be sent freight-prepaid to our factory location. When you return an instrument to Fluke Biomedical, we recommend using United Parcel Service, Federal Express, or Air Parcel Post. We also recommend that you insure your shipment for its actual replacement cost. Fluke Biomedical will not be responsible for lost shipments or instruments that are received in damaged condition due to improper packaging or handling.

Use the original carton and packaging material for shipment. If they are not available, we recommend the following guide for repackaging:

- Use a double-walled carton of sufficient strength for the weight being shipped.
- Use heavy paper or cardboard to protect all instrument surfaces. Use nonabrasive material around all projecting parts.
- Use at least four inches of tightly packed, industry-approved, shock-absorbent material around the instrument.

Returns for partial refund/credit:

Every product returned for refund/credit must be accompanied by a Return Material Authorization (RMA) number, obtained from our Order Entry Group at 1-440-498-2560.

Repair and calibration:

To find the nearest service center, go to [www.flukebiomedical.com/service](http://www.flukebiomedical.com/service) or

In the U.S.A. and Asia:  
Cleveland Calibration Lab  
Tel: 1-800-850-4608 x2564  
Email: [globalcal@flukebiomedical.com](mailto:globalcal@flukebiomedical.com)

In Europe, Middle East, and Africa:  
Eindhoven Calibration Lab  
Tel: +31-40-2675300  
Email: [ServiceDesk@fluke.com](mailto:ServiceDesk@fluke.com)

To ensure the accuracy of the Product is maintained at a high level, Fluke Biomedical recommends the product be calibrated at least once every 12 months. Calibration must be done by qualified personnel. Contact your local Fluke Biomedical representative for calibration.

---

### Certification

This instrument was thoroughly tested and inspected. It was found to meet Fluke Biomedical's manufacturing specifications when it was shipped from the factory. Calibration measurements are traceable to the National Institute of Standards and Technology (NIST). Devices for which there are no NIST calibration standards are measured against in-house performance standards using accepted test procedures.

---

### WARNING

Unauthorized user modifications or application beyond the published specifications may result in electrical shock hazards or improper operation. Fluke Biomedical will not be responsible for any injuries sustained due to unauthorized equipment modifications.

---

### Restrictions and Liabilities

Information in this document is subject to change and does not represent a commitment by Fluke Biomedical. Changes made to the information in this document will be incorporated in new editions of the publication. No responsibility is assumed by Fluke Biomedical for the use or reliability of software or equipment that is not supplied by Fluke Biomedical, or by its affiliated dealers.

---

### Manufacturing Location

The VT650/VT900A Gas Flow Analyzer is manufactured at Fluke Biomedical, 6920 Seaway Blvd., Everett, WA, U.S.A.

# Table of Contents

| Title                                  | Page |
|--|------|
| Introduction .....                     | 1    |
| Key Features .....                     | 1    |
| Safety Information .....               | 2    |
| Unpacking and Inspection .....         | 5    |
| Accessories .....                      | 6    |
| The Analyzer .....                     | 8    |
| Power On the Analyzer .....            | 10   |
| Analyzer Connections .....             | 12   |
| Airway Flow (Inlet and Exhaust) .....  | 12   |
| Ultra-Low Flow + and - (VT900A) .....  | 13   |
| High Pressure .....                    | 13   |
| Low Pressure (+ and -) .....           | 14   |
| Ultra-Low Pressure (VT900A only) ..... | 14   |
| Test Setup .....                       | 15   |
| Bi-directional Flow Mode .....         | 15   |

|                                       |    |
|---------------------------------------|----|
| Unidirectional Flow Mode .....        | 16 |
| Inspiratory Flow Connections .....    | 16 |
| Expiratory Test Connections .....     | 17 |
| Anesthesia Gas Connections .....      | 18 |
| Operations .....                      | 18 |
| Measured Signals .....                | 19 |
| Airway Flow .....                     | 19 |
| Airway Pressure .....                 | 19 |
| Airway Temperature and Humidity ..... | 20 |
| High Pressure .....                   | 20 |
| Low Pressure .....                    | 20 |
| Ultra-Low Pressure (VT900A) .....     | 20 |
| Ultra-Low Flow (VT900A) .....         | 21 |
| Barometric Pressure .....             | 21 |
| Oxygen Concentration .....            | 21 |
| Calculated Breath Parameters .....    | 21 |
| Anesthesia Gas .....                  | 22 |
| Excel Add-in .....                    | 25 |
| Measurements .....                    | 25 |
| Make a Measurement .....              | 25 |
| Save a Measurement .....              | 26 |
| Main Menu Functions .....             | 28 |
| Profiles Menu .....                   | 28 |
| Setup Menu .....                      | 29 |
| Units .....                           | 35 |
| Special Tests Menu .....              | 36 |

|  |    |
|--|----|
| Calibrate Oxygen .....                     | 37 |
| Customize Breath Views .....               | 38 |
| Memory Menu .....                          | 38 |
| Test ID .....                              | 38 |
| Maintenance, Service and Calibration ..... | 39 |
| Cleaning .....                             | 39 |
| Oxygen Sensor Replacement .....            | 40 |
| Battery Status .....                       | 40 |
| Battery Replacement .....                  | 41 |
| Replaceable Parts .....                    | 42 |
| Service and Calibration .....              | 42 |
| Specifications .....                       | 43 |
| Pressure .....                             | 44 |
| Flow .....                                 | 45 |





## ***Introduction***

The VT650/VT900A Gas Flow Analyzer (the Analyzer or Product), is a general purpose gas flow analyzer with special features for testing mechanical patient ventilators. The Analyzer measures bi-directional air flow, high and differential low pressure, barometric pressure, Oxygen concentration and airway pressure, airway temperature and airway humidity. The VT900A also measures ultra-low flow ( $\pm 750$  ml/min) and ultra-low pressure (0 mbar to 10 mbar). The Analyzer can be controlled externally using USB commands or automated with available software. The Analyzer operates on a rechargeable Li-Ion battery or external power supply for stationary or portable use. All figures show the VT900A unless otherwise noted.

## ***Key Features***

- Full range, bi-directional air flow and volume channel
- Ultra-low flow and pressure ranges (VT900A)
- High pressure, vacuum and differential low pressure
- Airway pressure, Oxygen concentration, temperature, and humidity
- Barometric pressure
- External trigger input (VT900A)
- Rechargeable Li-ion battery with up to 8 hours battery life
- USB port
- Customizable profiles that can be saved
- Numerical and graphical screens with real time data
- Automation software available
- On-board memory

## Safety Information

A **Warning** identifies conditions and actions that pose hazards to the user; a **Caution** identifies conditions and actions that may damage the Product or the equipment under test.

### Warning

To prevent possible electrical shock, fire, or personal injury:

- Read all safety information before you use the Product.
- Use the Product only as specified, or the protection supplied by the Product can be compromised.
- Carefully read all instructions.
- Do not use the Product around explosive gas, vapor, or in damp or wet environments.
- Use this Product indoors only.
- Do not use the Product if it operates incorrectly.
- Disable the Product if it is damaged.
- Do not use the Product if it is damaged.
- The battery door must be closed and locked before you operate the Product.
- Recharge the battery when the low battery indicator shows to prevent incorrect measurements. Low battery will also corrupt the memory card.
- Remove all probes, test leads, and accessories before the battery door is opened.
- Remove all probes, test leads, and accessories that are not necessary for the measurement.
- Use only specified replacement parts.
- Have an approved technician repair the Product.

- Batteries contain hazardous chemicals that can cause burns or explode. If exposure to chemicals occurs, clean with water and get medical aid.
- Do not disassemble the battery.
- Repair the Product before use if the battery leaks.
- Use only Fluke approved power adapters to charge the battery.
- Do not short the battery terminals together.
- Do not disassemble or crush battery cells and battery packs.
- Do not keep cells or batteries in a container where the terminals can be shorted.
- Do not put battery cells and battery packs near heat or fire. Do not put in sunlight.















- Remove the battery if the Product is not used for an extended period of time, or if stored in temperatures  $>50\text{ }^{\circ}\text{C}$ . If the battery is not removed, battery leakage can damage the Product.

** Caution**

To prevent possible damage, remove the O2 sensor if the Product is stored in temperatures  $>50\text{ }^{\circ}\text{C}$ .

Symbols used on the Analyzer and in this manual are explained in Table 1.

**Table 1. Symbols**

| Symbol  | Meaning  | Symbol  | Meaning   |
|---|--|---|---|
|  | WARNING. RISK OF DANGER.   |  | WARNING. HAZARDOUS VOLTAGE. Risk of electric shock.       |
|  | Consult user documentation.  |  | Conforms to European Union directives.                    |
|  | Power button   |  | Connected to power  |
|  | Battery  |  | Conforms to relevant North American Safety Standards.     |
|  | Li-ion Battery   |  | Conforms to relevant Australian Safety and EMC standards. |
|  | Power input 15 V dc 2.0 A  |  | Conforms to relevant South Korean EMC Standards.          |
|  | Conforms to the Appliance Efficiency Regulation (California Code of Regulations, Title 20, Sections 1601 through 1608), for small battery charging systems.  |   |   |
|  | This product complies with the WEEE Directive marking requirements. The affixed label indicates that you must not discard this electrical/electronic product in domestic household waste. Product Category: With reference to the equipment types in the WEEE Directive Annex I, this product is classed as category 9 "Monitoring and Control Instrumentation" product. Do not dispose of this product as unsorted municipal waste. |   |   |

## ***Unpacking and Inspection***

Make sure you do not damage the Analyzer as you unpack.

- Inspect the shipping carton for damage.
  - If there is no damage, remove the Analyzer from the shipping case. Save the box and packing materials.
  - If the shipping carton is damaged, carefully continue to unpack the Analyzer. Note any dents and scratches on the Analyzer. Save the damaged shipping carton and packing material for the carrier's inspection.
- Do a visual inspection. Make sure the Analyzer is intact. If there is any physical damage, such as bent or broken parts, dents, or scratches, call a Fluke Biomedical Service Center immediately. To return the Analyzer to Fluke Biomedical for service see *Returns and Repairs*.
- Check the standard accessories. If any accessories are missing, contact a Fluke Biomedical Service Center.

## Accessories

Table 2 is a list of the standard accessories provided with the Analyzer.

**Table 2. Standard Accessories**

| Item  | Part Number |
|---|-------------|
| USB Serial cable  | 4015274     |
| AC power adapter  | 4760480     |
| Accessory kit with:   | 4922115     |
| Bacterial filter for external connection to the flow ports (1)        | 2133712     |
| 1.2 m (4 ft) silicon tubing (2)                                       | 2237172     |
| 22 mm ID x 22 mm ID tubing adapters (2)                               | 2133305     |
| 22 mm OD x 22 mm OD tubing adapters (2)                               | 2133291     |
| Tapered 15 mm OD x 22 mm OD tubing adapters (2)                       | 2133269     |
| DISS Handtight Nut/Nipple to 6.4 mm (1/4 in) ID hose barb adapter (1) | 2216329     |
| Certificate of Calibration with test data                             | --          |

Table 3 is a list of optional accessories.

**Table 3. Optional Accessories**

| <b>Item</b>  | <b>Part Number</b> |
|--|--------------------|
| Soft-sided carrying case for ACCU-LUNG                 | 2397628            |
| ACCU LUNG II test lung                                 | 4281291            |
| ACCU-LUNG Lung Simulator with Soft-sided carrying case | 2387318            |
| VESA system mount                                      | 4969657            |
| VAPOR Anesthesia Tester                                | 5014709            |

## The Analyzer

Table 4 shows the top of the Analyzer.

Table 4. Top of the Analyzer

| Item | Description                     |
|------|---------------------------------|
| 1    | Touchsreen LCD                  |
| 2    | Flow exhaust                    |
| 3    | Flow inlet                      |
| 4    | Low pressure + and -            |
| 5    | High pressure and vacuum        |
| 6    | Ultra-low pressure (VT900A)     |
| 7    | Ultra-low flow + and - (VT900A) |
| 8    | Power button                    |



Table 5 shows the back of the Analyzer.

**Table 5. Back of the Analyzer**

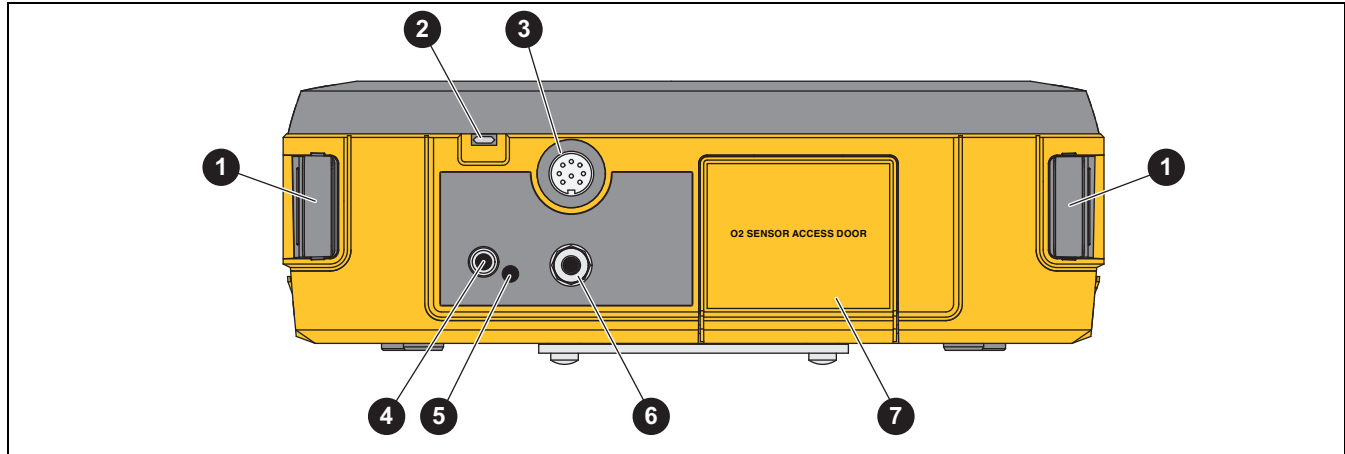

| Item | Description             | Item | Description                     |
|------|-------------------------|------|---------------------------------|
| 1    | Handle clip             | 5    | Battery status indicator        |
| 2    | USB port                | 6    | External trigger input (VT900A) |
| 3    | Accessory Port (VT900A) | 7    | Oxygen sensor door              |
| 4    | External dc power input |      |                                 |

Table 6 shows the bottom of the Analyzer.

Table 6. Bottom of the Analyzer

| Item | Description   |
|------|---|
| 1    | VESA mount points (FDMI MIS-C, fits W x H of 75 mm x 35 mm) |
| 2    | Oxygen sensor door screw                                    |
| 3    | Bail  |
| 4    | Battery door screws   |
| 5    | Battery door  |

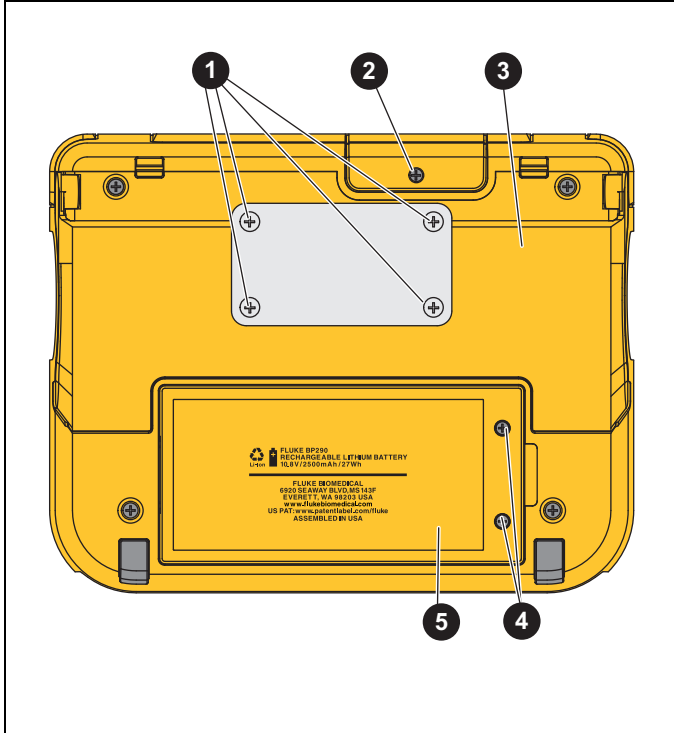

The diagram shows the bottom of the analyzer with five numbered callouts: 1 points to four VESA mount points on a silver plate; 2 points to a screw on the oxygen sensor door; 3 points to a bail on the right side; 4 points to two screws on the battery door; 5 points to the battery door itself. The battery door has a label with the following text: RECYCLE ♻️ FLUKE BP300 RECHARGEABLE LITHIUM BATTERY 10.8V/2500mAh/27Wh FLUKE BIOMEDICAL 690 BELLEVUE AVENUE SUITE 1000 EVERETT, WA 98203 USA www.flukebiomedical.com US PAT: www.patentlabel.com/Fluke ASSEMBLED IN USA

### **Power On the Analyzer**

To power on the Analyzer, push .

The Analyzer defaults to the Airway screen.  
Table 7 shows the main screen of the Analyzer.

To make a selection, tap the screen.

**Table 7. Example of Airway Measurement**

The screenshot shows a mobile application interface for 'Airway' measurement. At the top, there is a header bar with 'Airway', 'FACTORY PROFILE', 'Air', and 'ATP'. Below this is a battery icon. The main display area shows four rows of measurements: Flow (0.00 lpm), Pressure (0.00 cmH2O), Volume (0.001 l), and Oxygen (20.9 %). On the left side, there is a vertical menu with options: Airway, Breath Views, High Pressure, Low Pressure, Ultra-Low Pressure, Ultra-Low Flow, and a Menu icon. At the bottom, there is a blue bar with five buttons: Zero, Graph, More Data, Profiles, and Save. Six numbered callouts (1-6) are placed around the screen to identify specific UI elements: 1 points to the left menu, 2 points to the 'Airway' header, 3 points to the 'ATP' header, 4 points to the battery icon, 5 points to the main measurement display area, and 6 points to the bottom navigation bar.

| Item | Description                 | Item | Description    |
|------|-----------------------------|------|----------------|
| 1    | Measurement and other menus | 4    | Battery symbol |
| 2    | Selected Profile            | 5    | Display area   |
| 3    | Measurement settings        | 6    | Screen options |

## **Analyzer Connections**

You can connect the Analyzer to a ventilator and test lung in either a bi-directional or unidirectional flow configuration.

### ***Airway Flow (Inlet and Exhaust)***

The outer diameter of the airway port is a standard 22 mm fitting for use with patient hoses. The inner diameter of the airway port accepts a 15 mm male respiratory fitting for use with endotracheal tubes, gas sampling adapters, and similar equipment.

#### **⚠ Caution**

**To avoid damage to the Analyzer and avoid adverse affects on the Analyzer performance:**

- **Do not put metal objects into connectors.**

- **Always use the external flow filter on the main airflow channel inlet. This helps reduce turbulence and keeps out small particles that could damage the flow sensor.**
- **To avoid damage to the sensor, make sure the pressure inside the airway port does not exceed 5 psi.**
- **Measure only dry gases with the airway port. Do not use this port to measure humidified gases.**

### ***Ultra-Low Flow + and - (VT900A)***

The + and - ultra-low-flow ports have a barbed hose fitting connection.

#### **⚠ Caution**

**To avoid damage to the Analyzer and avoid adverse affects on the Analyzer performance:**

- **To avoid damage to the sensor, make sure the pressure inside the ultra-low-flow port does not exceed 25 psi.**
- **Measure only dry gases with the ultra-low-flow port. Do not use this port to measure humidified gases.**

### ***High Pressure***

The high-pressure port is primarily to test wall and tank pressurized gas sources. The connector works with standard oxygen DISS fittings, as used on oxygen supply hoses.

#### **⚠ Caution**

**To avoid damage to the Analyzer and avoid adverse affects on the Analyzer performance:**

- **To avoid damage to the sensor, make sure applied pressure does not exceed 188 psi (13 bar).**
- **Measure only dry gases with the high-pressure port. Do not use this port to measure fluid pressure.**

### *Low Pressure (+ and -)*

Measure differential low pressure between the + and - ports or gauge pressure on either port. Connectors are barbed hose fittings.

#### **⚠ Caution**

**To avoid damage to the Analyzer and avoid adverse affects on the Analyzer performance:**

- **To avoid damage to the sensor, make sure applied pressure does not exceed 5 psi.**
- **Measure only dry gases with the low-pressure port. Do not use this port to measure fluid pressure.**

### *Ultra-Low Pressure (VT900A only)*

The ultra-low pressure port has a barbed hose fitting connection.

#### **⚠ Caution**

**To avoid damage to the Analyzer and avoid adverse affects on the Analyzer performance:**

- **To avoid damage to the sensor, make sure applied pressure does not exceed 5 psi.**
- **Measure only dry gases with the ultra-low-pressure port. Do not use this port to measure fluid pressure.**

## Test Setup

Use the airway port for ventilator testing. Use a test lung to set up a test that measures ventilator parameters in bi-directional or uni-directional modes. Fluke Biomedical recommends the bi-directional mode.

## Bi-directional Flow Mode

For bi-directional flow connections, see Figure 1.

1. Use a Y-piece adapter to connect the ventilator to the flow inlet on the Analyzer.
2. Use a standard breathing hose to connect to the exhaust port on the Analyzer.

The Analyzer shows the flow of gas delivered by the ventilator.

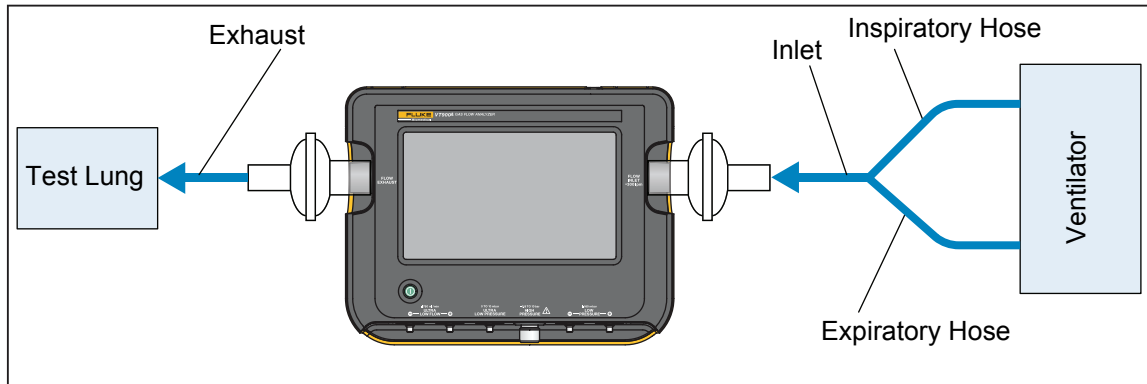

Figure 1. Bi-Direction Flow Mode Connections

## Unidirectional Flow Mode

Use the unidirectional flow to measure either inspiratory or expiratory gas flow.

## Inspiratory Flow Connections

For inspiratory connections, see Figure 2.

1. Connect the inspiratory hose to the flow inlet on the Analyzer.
2. Use a standard breathing hose to connect the test lung to the exhaust port on the Analyzer.

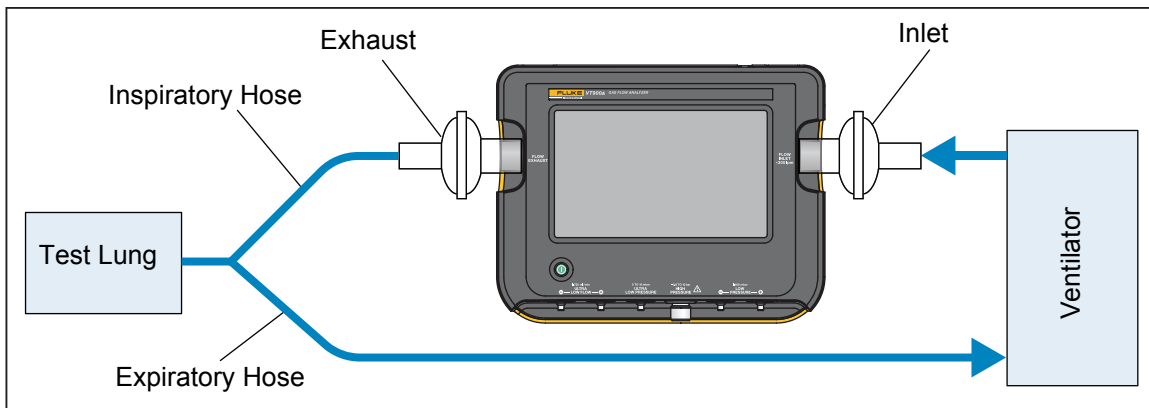

**Figure 2. Inspiratory Breathing Circuit Connections**



### Expiratory Test Connections

For expiratory connections, see Figure 3.

1. Connect the expiratory hose from the test lung to the flow inlet on the Analyzer.

2. Use a standard breathing hose to connect the ventilator to the exhaust port on the Analyzer.

The Analyzer shows the flow of gas delivered by the ventilator.

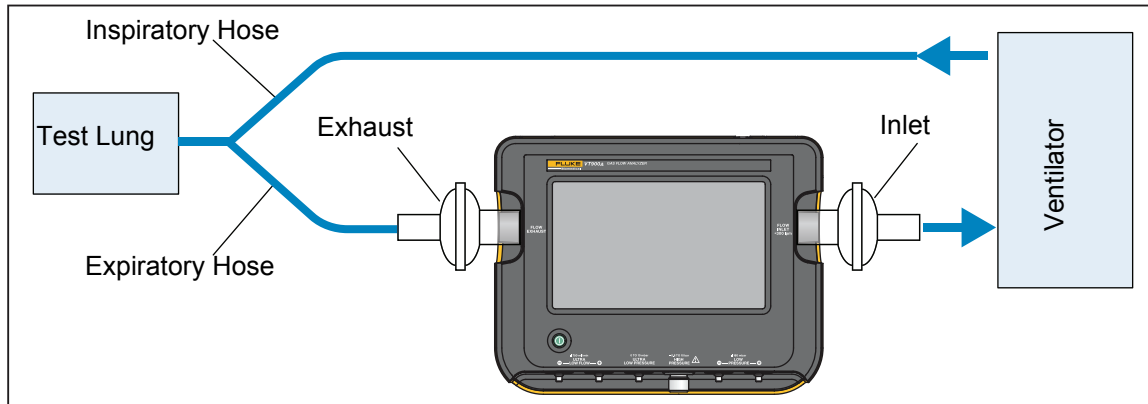

**Figure 3. Expiratory Breathing Circuit Connections**

## Anesthesia Gas Connections

Use the VAPOR accessory with the Analyzer to measure anesthesia gas concentrations. For more information see *Anesthesia Gas*.

VAPOR connections are shown in Figure 4.

## Operations

Use the Analyzer to measure flow and pressure. For each test, select the test and do the setup.

Displayed options depend on the selected test:

- **Zero**—Corrects sensor offsets for the selected measurements.
- **Graph**—Select the parameters to graph.
- **Back**—Return to the previous screen.
- **Clear**—Clear the graph and statistics (minimum, maximum, and average).
- **Autoscale**—Toggles between Autoscale and manual scale.
- **Profiles**—Select a different profile.
- **Save**—Saves the final result.

## **Measured Signals**

The Analyzer measures these signals:

- Airway flow
- Airway pressure
- Airway temperature and humidity
- High pressure
- Low pressure
- Ultra-low pressure (VT900A)
- Ultra-low flow (VT900A)
- Barometric pressure
- Oxygen concentration
- Calculated breath parameters
- Anesthesia gas concentration (VT900A with optional VAPOR accessory)

## **Airway Flow**

The Analyzer has a full-range flow ( $\pm 300$  lpm), with bi-directional flow measurement. Flow measurements are either *static flows*—no breath variations, or *ventilator waveforms*—both an expiratory phase and an inspiratory phase. The Analyzer uses a heat transfer sensor to measure the flow.

Use this measurement for pediatric or adult ventilators or to determine the performance of many types of flow meters.

## **Airway Pressure**

The Analyzer measures airway pressure from a proximal tap of the channel (near the exhaust port).

### *Airway Temperature and Humidity*

There is a temperature / humidity sensor in the airway channel on the exhaust side of the flow sensor. The Analyzer uses the temperature reading to automatically adjust for the gas corrections (see Table 11).

Tap **More Data** on the Airway screen to see temperature and humidity.

### *High Pressure*

The high-pressure port measures gauge pressure in the range of -0.8 bar to 10 bar. The Analyzer can use this pressure measurement for any gauge pressure in the given range.

### *Low Pressure*

The low-pressure port is a dual-port connection consisting of a (+) positive and a (-) negative pressure port.

The differential pressure range is  $\pm 160$  mbar. Use this pressure measurement for any pressure differential or gauge pressure in the given range.

### *Ultra-Low Pressure (VT900A)*

The ultra-low pressure sensor measures gauge pressure in the range of 0 mbar to 10 mbar. Use this pressure range for accurate, very low pressure measurements.

### ***Ultra-Low Flow (VT900A)***

The Analyzer (VT900A only) has ultra-low flow ( $\pm 750$  ml/min) bi-directional flow measurement capability. The flow measurement is for accurate, high resolution, static low flow measurements, not for ventilator waveforms. The flow sensor uses the heat transfer method to measure air flow. Use the ultra-low flow to measure many types of low flow meters.

### ***Barometric Pressure***

The Analyzer makes barometric pressure measurements. The barometer reads absolute pressures from 8 psia to 18 psia. The Analyzer also uses the barometer in the automatic gas corrections for airway flow measurements.

### ***Oxygen Concentration***

The Analyzer measures oxygen concentration through the airflow channel. An integrated sensor measures the oxygen percent of the gas in the airflow channel of the Analyzer. The range for this sensor is 0 % to 100 %. The oxygen cell is mounted inside the enclosure on the rear bulkhead for the high-flow circuit. The oxygen cell must be replaced approximately once a year (VT650) or every 2 years (VT900A).

### ***Calculated Breath Parameters***

From the primary flow and pressure measurements, the Analyzer calculates breath parameters. A breath detection algorithm determines the various phases of a ventilator breath and calculates the parameters listed in Table 15.

## Anesthesia Gas

VAPOR samples anesthesia gases and automatically detects the significant components. These concentrations are shown:

- **Primary** - the highest gas concentration.
- **Secondary** - the next highest gas concentration.

VAPOR measures these anesthesia gases:

- HAL Halothane
- ENF Enflurane
- ISO Isoflurane
- SEV Sevoflurane
- DES Desflurane

VAPOR also measures:

- N2O Nitrous Oxide
- CO2 Carbon Dioxide

When VAPOR is connected and the Analyzer is ON, the Airway menu shows the **Anesthesia** button.

Use the Anesthesia menu to control VAPOR. The Anesthesia menu also displays the status of VAPOR. Options are:

- **On**—Turns on VAPOR. Each time VAPOR turns on VAPOR does a self-test and starts a 10 minute warm up until Full accuracy. (Warmup accuracy is available in 45 seconds.)
- **Off**—Turns off VAPOR.
- **Sleep**—Keeps VAPOR at the same accuracy and minimizes battery usage.
- **Wake**—Starts VAPOR at the same accuracy after Sleep mode.
- **Save**—Saves displayed data or does a timed recording.

To use the VAPOR accessory:

1. Make these connections to VAPOR (see Figure 4):
  - a. Connect the 22 mm T fitting in line with the anesthesia gas flow.
  - b. Connect the gas sampling line with quick connect fitting to the Input port.
  - c. Connect the Exhaust port to a gas scavenging system.
4. Connect the VAPOR electrical cable to the Analyzer accessory port.
5. Turn on the Analyzer.

When VAPOR is connected and the Analyzer is ON, the Airway menu shows the **Anesthesia** button.

6. Tap **Anesthesia**.
7. Tap **On** to turn on VAPOR.

For more information on Warmup and Full accuracy, see the *VAPOR Instructions*.

 **Caution**

**Do not connect anesthesia gas to the Analyzer airway channel. Anesthesia gas can damage the sensor in the Analyzer.**

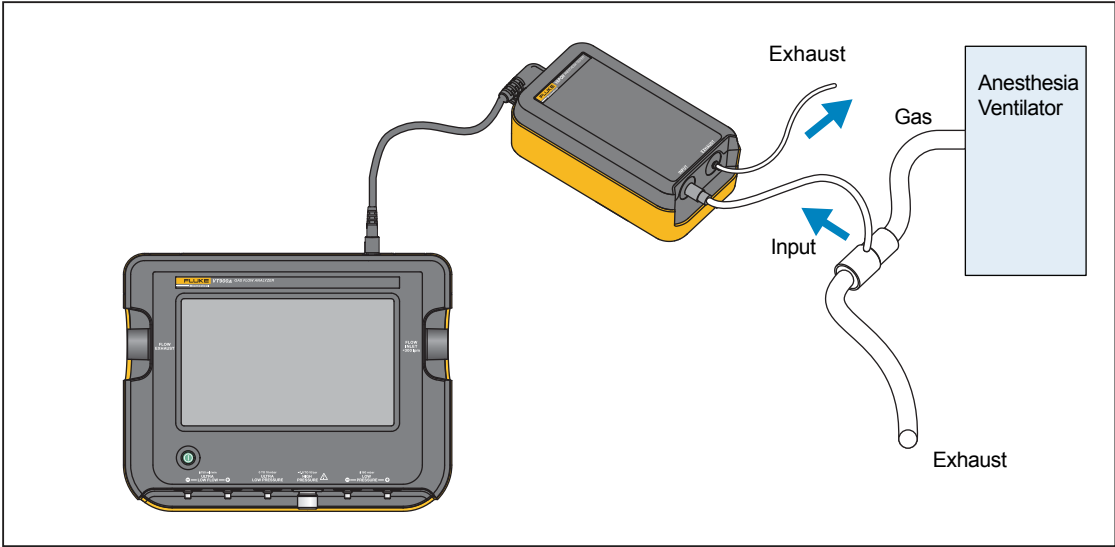

**Figure 4. Anesthesia Gas Connections**



## Excel Add-in

Install custom Excel add-in, available for download at [www.flukebiomedical.com](http://www.flukebiomedical.com). Use the Excel Add-in on a PC to view results data. The Excel Add-in has these worksheets:

- **Data** – shows saved data
- **Recording** – shows recorded data
- **Graph** – shows graphs and data

## Measurements

Table 8 is an example of the measurement screen.

### Make a Measurement

To make a measurement:

1. Select the type of measurement.
2. To set the offset to zero, tap **Zero**. Make sure to remove all the connections.

#### *Note*

*You may need to block the airflow channel if room air currents are present.*

3. To switch between Auto and manual scaling, tap **Autoscale**.

## Save a Measurement

The Analyzer can save readings or start a recording to save.

To save a measurement:

1. On the measurement screen, tap **Save**.
2. Select the type of reading you want to save.
  - **Data**—The current data points.
  - **Graph**—The current data points in a graphical format.
  - **Record**—Set up the parameters and start a new recording to save.

Table 8. Example of Measurement

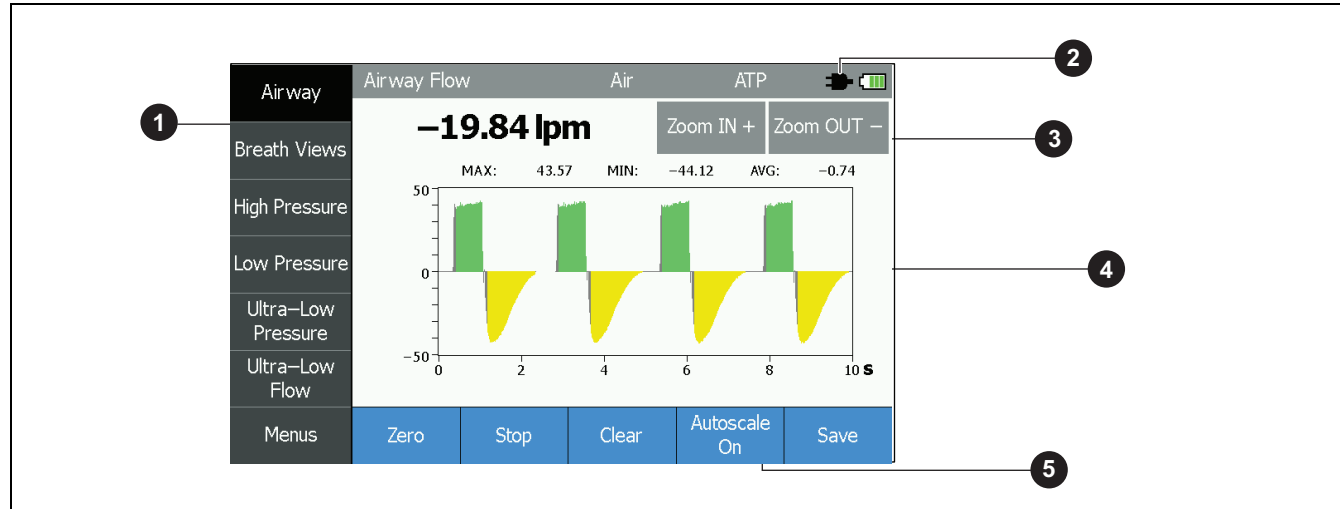

| Item | Description        | Item | Description                        |
|------|--------------------|------|------------------------------------|
| 1    | Measurements       | 4    | Graph area                         |
| 2    | Connected to power | 5    | Toggle manual or automatic scaling |
| 3    | Change scaling     |      |                                    |

## Main Menu Functions

Use the Main menu to access the Analyzer functions, including:

- Profiles
- Setup
- Units
- Special Tests
- Memory
- Customize Breath Views
- Calibrate Oxygen
- Test ID

## Profiles Menu

You can configure the settings on the Analyzer to create test profiles. The analyzer can save up to 20 profiles.

The Analyzer stores the profiles using a numeric code and a profile name. 00 is the default numeric code. You cannot change the 00 default profile. An asterisk (\*) indicates the profile that will be loaded at start up.

To select a profile, use the arrow keys.

To manage profiles, select **Menus > Profile** or tap **Profile** on the Airway screen.

Options are:

- **View Current**—View the settings for the current profile loaded on the Analyzer. Tap **More** for another page of settings.
- **View Selection**—View the settings of the highlighted profile in the profile list. Tap **More** for another page of settings.

- **\*Use on Power-Up**—Make the selected profile the default profile.
- **Back**—Go to the main Profile menu.
- **Edit Name**—Change the name of the selected profile.
- **Load**—Select a profile to load. If there are no saved profiles, the option is **Default**.
- **Save**—Saves the current profile.

### *Setup Menu*

Use the Setup menu to make and view the Analyzer settings.

To setup the Analyzer, select **Menus > Setup**.

For Setup selections, see Table 9.

**Table 9. Setup Menu**

| <b>Setup</b>           | <b>Description</b>   |
|------------------------|--|
| <b>Gas</b>             | Select the type of gas. See Table 10.  |
| <b>Correction Mode</b> | Select the type of Gas correction (temperature and pressure) to different gas standards. See Table 11. |

Table 9. Setup Menu (cont.)

| Setup                | Description   |
|----------------------|---|
| <b>Breath Detect</b> | <p>Sets the options for Breath Detection. Options are:</p> <ul style="list-style-type: none"> <li>• <b>Mode</b> - Sets the breath detection mode: <ul style="list-style-type: none"> <li>○ <b>Bidirectional</b></li> <li>○ <b>Uni-directional Inspiratory</b></li> <li>○ <b>Uni-directional Expiratory</b></li> <li>○ <b>Off</b> - disables breath triggering</li> </ul> </li> <li>• <b>Trigger Source</b> - Sets how the breath detection is triggered: <ul style="list-style-type: none"> <li>○ <b>Flow</b> - Set the Threshold</li> <li>○ <b>Pressure</b> - Requires back pressure, such as a test lung</li> <li>○ <b>External</b> - enables external TTL triggering input on the Analyzer (VT900A)</li> </ul> </li> <li>• <b>Patient</b> - Sets the type of patient: <ul style="list-style-type: none"> <li>○ <b>Adult</b></li> <li>○ <b>Pediatric</b></li> </ul> </li> <li>• <b>Threshold</b> - Enter the numeric value for the detection limit. <ul style="list-style-type: none"> <li>○ <b>+</b> (Inspiratory threshold)</li> <li>○ <b>-</b> (Expiratory threshold)</li> </ul> </li> </ul> |

**Table 9. Setup Menu (cont.)**

| <b>Setup</b>                  | <b>Description</b>   |
|-------------------------------|--|
| <b>Instrument Information</b> | <p>Displays basic information about the Analyzer including:</p> <ul style="list-style-type: none"> <li>• Model number</li> <li>• Serial number</li> <li>• Firmware version</li> <li>• Date of calibration</li> <li>• Battery charge level</li> <li>• Memory remaining</li> </ul> |
| <b>Auto Dim</b>               | <p>Options are:</p> <ul style="list-style-type: none"> <li>• <b>On</b> - The LCD dims after 5 minutes of no use. Tap to restore brightness.</li> <li>• <b>Off</b> - The LCD does not auto dim.</li> </ul>  |
| <b>Beeper</b>                 | <p>Options are:</p> <ul style="list-style-type: none"> <li>• <b>Off</b></li> <li>• <b>Soft</b></li> <li>• <b>Medium</b></li> <li>• <b>Loud</b></li> </ul>  |

Table 9. Setup Menu (cont.)

| Setup                | Description  |
|----------------------|--|
| <b>Time and Date</b> | Options are: <ul style="list-style-type: none"><li>• <b>Set Time Format</b> - Select <b>12 hour</b> with am/pm or <b>24 hour</b>.</li><li>• <b>Set Time</b> - Tap the arrows to set the time. If in 12-hour format, select am or pm.</li><li>• <b>Set Date Format</b> - Select <b>MM/DD/YYYY</b>, <b>DD/MM/YYYY</b>, or <b>YYYY/MM/DD</b>.</li><li>• <b>Set Date</b> - Tap the arrows to set the date.</li></ul> |
| <b>Brightness</b>    | Options are: <ul style="list-style-type: none"><li>• <b>Low</b></li><li>• <b>Medium</b></li><li>• <b>High</b></li></ul>  |
| <b>Language</b>      | Select the language.   |



**Table 10. Gas Types**

| <b>Gas Type</b>   | <b>Description</b>                     |
|---|--|
| Air   | Standard room air                      |
| N2  | 100 % Nitrogen                         |
| N2O   | 100 % Nitrous Oxide                    |
| CO2   | 100 % Carbon Dioxide                   |
| O2  | 100 % Oxygen                           |
| Ar  | 100 % Argon                            |
| Heliox  | 21 % Oxygen, and 79 % Helium           |
| O2 bal N2O mix <sup>[1]</sup>   | Measured Oxygen, balance Nitrous Oxide |
| O2 bal He mix <sup>[1]</sup>  | Measured Oxygen, balance Helium        |
| O2 bal N2 mix <sup>[1]</sup>  | Measured Oxygen, balance Nitrogen      |
| <p><sup>[1]</sup> For these gases, the oxygen concentration is measured using the oxygen sensor in the airflow channel. The balance is the other gas. These gases can only be measured in the airflow channel, not available in the ultra-low-flow channel of the VT900A.</p> |  |

Table 11. Gas Correction Mode

| Gas Correction  | Description  |
|---|--|
| ATP   | Ambient temperature and pressure (actual humidity)                         |
| ATPD  | Ambient temperature and pressure, dry (0 % humidity)                       |
| ATPS  | Ambient temperature and pressure, saturated (100 % humidity)               |
| STP20   | Standard temperature 20 °C, standard pressure 760 mmHg (actual humidity)   |
| STP21   | Standard temperature 21 °C, standard pressure 760 mmHg (actual humidity)   |
| STPD0   | Standard temperature 0 °C, standard pressure 760 mmHg, dry (0 % humidity)  |
| STPD20  | Standard temperature 20 °C, standard pressure 760 mmHg, dry (0 % humidity) |
| STPD21  | Standard temperature 21 °C, standard pressure 760 mmHg, dry (0 % humidity) |
| BTPS  | Body temperature 37 °C, ambient pressure, saturated (100 % humidity)       |
| BTPD  | Body temperature 37 °C, ambient pressure, dry (0 % humidity)               |
| Note: Gas correction applies to the airflow channel. The ultra-low-flow channel of the VT900A is set to STPD21. |  |

## Units

You can change the units of measure for all readings.

To set the units:

1. Select **Menus > Units**.
2. Select the type of reading.
3. Select the unit of measure. See Table 12.
4. Select **OK**.

**Table 12. Available Units of Measure**

| Unit        | Description            |
|-------------|------------------------|
| <b>Flow</b> |                        |
| lpm         | Liters per minute      |
| lps         | Liters per second      |
| mlpm        | Milliliters per minute |
| mlps        | Milliliters per second |
| cfm         | Cubic feet per minute  |

**Table 12. Available Units of Measure (cont.)**

| Unit               | Description |
|--------------------|-------------|
| <b>Volume</b>      |             |
| l                  | Liters      |
| ml                 | Milliliters |
| cf                 | Cubic feet  |
| <b>Temperature</b> |             |
| °C                 | Celsius     |
| °F                 | Fahrenheit  |

Table 12. Available Units of Measure (cont.)

| Unit               | Description            |
|--------------------|------------------------|
| <b>Pressure</b>    |                        |
| mbar               | millibar = 0.001 bar   |
| bar                | 14.7 psi               |
| mmHg               | Millimeters of mercury |
| inHg               | Inches of mercury      |
| cmH <sub>2</sub> O | Centimeters of water   |
| inH <sub>2</sub> O | Inches of water        |
| psi                | Pounds per square inch |
| atm                | Atmosphere             |
| kPa                | Kilopascals            |

### *Special Tests Menu*

Use the Special Tests menu for more tests.

Leak Tests calculate the lost volume over the specified time. To do a leak test:

1. Select **Menus > Special Tests**.
2. Select the type of leak test:
  - Airway Pressure
  - High Pressure
  - Low Pressure
  - Ultra-Low Pressure
3. Use the keypad to enter the length of the test.
4. Tap **Compliance** and use the keypad to enter the compliance limit.

Use compliance to calculate volume lost. For example, enter the ml of volume lost per cmH<sub>2</sub>O. If blank, volume lost is not calculated.

5. Tap **Start**.

Trend Tests show how a particular breath parameter performs over time. To do a trend test:

1. Select **Menus > Special Tests > Trend Test**.
2. Use the arrows to select the parameter to measure.
3. Use the keypad to enter the % limit for maximum allowed deviation.
4. Tap **Start**.

The Stacked Volume Test measures the volume of multiple breaths. Breath volume determines the accuracy of the ventilator in accumulating volume.

1. Select **Menus > Special Tests > Stacked Volume Test**.
2. Use the key pad to enter the number of breaths.
3. Select **Start**.

The test stops when the number of breaths is reached or you select **End**.

The High Frequency Test measures high-frequency flow and airway pressure.

1. Select **Menus > Special Tests > High Frequency Test**.
2. Apply the high-frequency flow or pressure.

### *Calibrate Oxygen*

Calibrate the oxygen sensor at the beginning of each day that oxygen will be measured, and after replacing the sensor.

To calibrate the sensor:

1. Select **Menus > Calibrate Oxygen**.
2. Follow the on-screen instructions. Make sure to complete both steps.

If the calibration fails, replace the Oxygen sensor. If the problem persists, contact Fluke Biomedical for repair.

## *Customize Breath Views*

Use Customize Breath Views to configure custom breath screens with up to eight readings each. Select the Airway or the Breath parameters to show.

## *Memory Menu*

Use Memory to manage stored readings.

1. Select **Menus > Memory**.
2. Select **List**.

Options are:

- **Back**—Go back to the previous screen.
- **View**—Views the selected reading.
- **Delete**—Deletes the selected reading.
- **Delete All**—Deletes all readings.

## *Test ID*

Use the Test ID to identify saved test data. Use the keyboard to enter a Test ID. When viewing Memory, select a Test ID to see the saved data.

## **Maintenance, Service and Calibration**

The Analyzer requires little maintenance or special care; however it is a calibrated measuring instrument and should be treated with care.

### **Caution**

**To prevent damage to the Analyzer or adverse affects on the Analyzer performance, do not drop the Analyzer and avoid mechanical abuse that could cause a shift in the calibrated settings.**

Fluke Biomedical recommends storing the Analyzer in the carry case. Do not store the Analyzer where there is vibration.

During use, always use the external flow filter on the main airflow channel inlet. The filter helps reduce turbulence and keeps out small particles that could damage the flow sensor.

## **Cleaning**

Clean the exterior of the Analyzer occasionally with a cloth dampened with a mild detergent solution. To remove stains and clean the Analyzer, use a solution of 70 % isopropyl alcohol. Fluke Biomedical does not recommend any other solvents.

### **Caution**

**To prevent damage to the Analyzer or adverse affects on the Analyzer performance, do not spray liquid directly on the Analyzer. Do not immerse the Analyzer.**

## Oxygen Sensor Replacement

The Analyzer uses a galvanic oxygen sensor that is under warranty for 12 months. You must replace the oxygen sensor cell when the oxygen calibration cannot be successfully completed. The oxygen sensor can operate for longer than 12 months depending on use. With normal use the VT650 oxygen sensor will last 12 months and the VT900A oxygen sensor will last 24 months.

To replace the oxygen sensor:

1. Remove the screws in the oxygen sensor door on the back of the Analyzer.  
The oxygen sensor is a round plastic cylinder about one inch in diameter with wires protruding from the back of the sensor.
2. Disconnect the electrical connector on the sensor wire.
3. Unscrew the old sensor and remove it.
4. Screw in the new sensor. (See *Replaceable Parts*).

5. Re-connect the sensor wire.
6. Replace the oxygen sensor door.
7. Re-calibrate the oxygen sensor. (See *Calibrate Oxygen*.)

## Battery Status

The Battery status indicator on the back of the Analyzer has these normal states:

- Solid red—Battery is charging
- Solid green—Battery is 100 % charged

The battery has these error states:

- Blinking red—Battery charger error
- Blinking red/green—Battery charger error (Battery is near full charge.)

For these errors, remove the ac adapter and reinstall. If the problem reoccurs, replace the battery pack. If the problem persists, contact Technical Support.



## **Battery Replacement**

To check the battery charge level, remove the battery door and push the TEST button on the battery. The battery displays the percentage of charge.

Use only the replacement battery listed in Table 13.

To replace the battery (See Figure 5):

1. Loosen the screws on the battery door. (The screws do not come out.)
2. Remove the battery door.
3. Use the strap on the battery to lift out the battery.
4. Insert the new battery and replace the battery door.

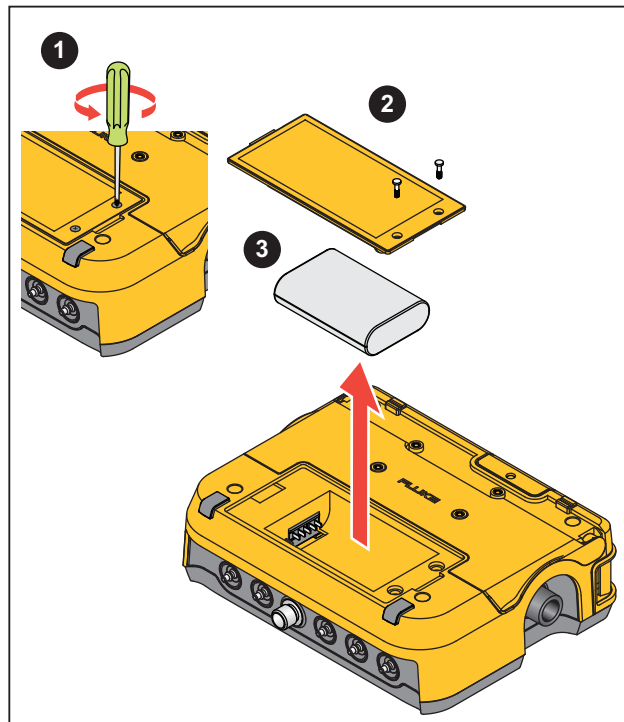

**Figure 5. Battery Replacement**

## Replaceable Parts

Table 13 is a list of the replaceable parts for the Analyzer.

**Table 13. Replaceable Parts**

| Item                           | Fluke Part Number |
|--------------------------------|-------------------|
| Oxygen sensor (VT650)          | 2138514           |
| Oxygen sensor (VT900A)         | 4917220           |
| O2 sensor door                 | 4916215           |
| Battery Door                   | 4916194           |
| Battery Pack                   | 4948749           |
| Protective cap (High-pressure) | 2133735           |
| Protective caps (Flow)         | 2133758           |
| Protective caps (Pressure)     | 4918975           |

## Service and Calibration

To maintain accuracy, calibrate the Analyzer annually. If the Analyzer does not operate successfully or if it needs calibration, return it to the Fluke Biomedical Service Center, as indicated under *Warranty and Product Support*. As part of this service, hardware and software updates are automatically installed.

### Caution

**To prevent damage to the Analyzer or adverse affects on the Analyzer performance:**

- **Other than replacement of minor components, such as the oxygen sensor, all Analyzer service should be done by qualified service personnel.**

- **To keep foreign debris from entering the Analyzer, use flow and pressure protective caps when transporting the Analyzer.**
- **To keep the Analyzer under warranty, make sure the Analyzer is calibrated by qualified service personnel only.**

## **Specifications**

Specifications are based on a one year calibration cycle and apply to ambient temperature 18 °C to 28 °C unless stated otherwise.

Display .....7 in, 800 x 480 touchscreen LCD

Communications .....USB, Micro-B Device Port

### **Environmental Conditions**

Operating Temperature ..... 10 °C to 40 °C

Storage Temperature.....-20 °C to +60 °C

#### *Note*

*For storage temperatures below -15 °C or above +50 °C, remove the oxygen sensor.*

Operating Humidity ..... 10 % to 90 % non-condensing

Storage Humidity .....5 % to 95 % non-condensing

Altitude.....3000 m

### **Power**

AC adapter

Input Voltage Range ..... 100 V ac to 240 V ac

Input Frequency

Range .....50 Hz/60 Hz

DC Output.....15 V, 2 A

Polarity.....Center positive (+)

**Battery**

Rechargeable Li-Ion

Battery ..... 10.8 V, 2.5 Ah, 27 Wh, 3ICR19/66

Discharge temperature... 0 °C to 50 °C

Charge temperature ..... 0 °C to 40 °C

Battery life ..... 8 hours

Battery charge time ..... 5 hours, typical

*Note*

*Battery life is dependent on backlight brightness, auto-dim, and other battery intensive settings.*

**Pressure**

**Ultra Low Pressure (VT900A)**

Maximum applied

pressure ..... 400 mbar

Operating Pressure ..... 0 mbar to 10 mbar

Span Accuracy .....  $\pm 1\%$  of rdg or  $\pm 0.01$  mbar  
(whichever is greater)

Resolution ..... 0.001 mbar

**Low Pressure**

Maximum applied

pressure ..... 400 mbar

Operating Pressure ..... (Differential)  $\pm 160$  mbar

Span Accuracy .....  $\pm 0.5\%$  of rdg or  $\pm 0.1$  mbar  
(whichever is greater)

Resolution ..... 0.01 mbar

**High Pressure**

Maximum applied

pressure ..... 13 bar

Operating Pressure ..... -0.8 bar to 10 bar

Span Accuracy .....  $\pm 1\%$  of rdg or  $\pm 7$  mbar (whichever  
is greater)

Resolution ..... 1 mbar

**Airway Pressure**

Maximum applied

pressure ..... 400 mbar

Operating Pressure .....  $\pm 160$  mbar

Span Accuracy .....  $\pm 0.5\%$  of rdg or  $\pm 0.1$  mbar  
(whichever is greater)

Frequency Response ..... 10 % to 90 % rise time <10 ms

Resolution ..... 0.01 mbar

Sample rate .....  $\geq 200$  Hz

**Pressure Temperature**

Coefficient ..... Add 0.01 % of range per °C  
between 10 °C and 18 °C  
Add 0.01 % of range per °C  
between 28 °C and 40 °C

## Flow

### Airway Flow

Resolution .....0.01<100 slpm and  
0.1 >100 slpm  
Accuracy .....see Table 14  
Frequency Response.....10 % to 90 % rise time <10 ms  
Sample Rate.....≥200 Hz  
Dynamic Resistance .....<2.00 cmH<sub>2</sub>O @ 60 slpm

### Ultra-Low-Flow (VT900A)

Range .....±750 ml/min  
Accuracy .....±1.7 % of rdg or 0.01 slpm  
Resolution.....0.001 lpm

**Table 14. Airway Flow Range and Accuracy**

| Gas  | Range     | Specification                         |
|--|-----------|---------------------------------------|
| Main Airway Flow   |           |                                       |
| Air, Nitrogen (N <sub>2</sub> ),<br>Oxygen (O <sub>2</sub> )               | ±300 slpm | 1.7 % of rdg or<br>0.04 slpm          |
| Argon, Heliox,<br>O <sub>2</sub> bal He, O <sub>2</sub> bal N <sub>2</sub> | ±300 slpm | 3.0 % of rdg or<br>0.08 slpm, typical |

**Table 14. Airway Flow Range and Accuracy (cont.)**

| Gas   | Range       | Specification                         |
|---|-------------|---------------------------------------|
| Carbon Dioxide (CO <sub>2</sub> ),<br>Nitrous Oxide (N <sub>2</sub> O),<br>O <sub>2</sub> bal N <sub>2</sub> O, | ±150 slpm   | 3.0 % of rdg or<br>0.08 slpm, typical |
| Ultra-low Flow (VT900A)   |             |                                       |
| Air, Nitrogen (N <sub>2</sub> ),<br>Oxygen (O <sub>2</sub> )  | ±0.750 slpm | 1.7 % of rdg or<br>0.01 slpm          |
| Argon   | ±0.750 slpm | 3.0 % of rdg or<br>0.02 slpm, typical |
| Nitrous Oxide (N <sub>2</sub> O)  | ±0.400 slpm | 3.0 % of rdg or<br>0.02 slpm, typical |
| <i>Note: Ultra-low flow that is over range can be detected as unstable. If this occurs, reduce flow.</i>        |             |                                       |

### Flow Temperature

Coefficient.....Add 0.2 % of reading per °C  
between 10 °C and 18 °C  
Add 0.2 % of reading per °C  
between 28 °C and 40 °C

Volume (Airway Flow channel)

- Range..... 100 l
- Accuracy ..... ±1.75 % rdg or 0.02 l  
(whichever is greater)
- Resolution ..... 0.001 l, 0.1 ml

Temperature and Humidity (Airway Flow channel)

- Temperature range ..... 0 °C to 50 °C
- Temperature accuracy\* ..... ±0.5 °C
- Temperature resolution ..... 0.1 °C
- Humidity range ..... 0 % to 100 % RH
- Humidity accuracy\* ..... 3 % RH from 20 % to 80 % RH  
5 % RH < 20 %, and >80 % RH
- Humidity resolution..... 0.1 % RH

*\* with steady state air flow*

Oxygen concentration (Airway Flow channel)

- Range..... 0 % to 100 %
- Accuracy ..... ±1 % (VT900A), ±2 % (VT650)
- Resolution ..... 0.1 %

Gas correction

See Table 11.

Gas types

Air, Nitrogen (N<sub>2</sub>), Nitrous Oxide (N<sub>2</sub>O), Carbon Dioxide (CO<sub>2</sub>), Oxygen (O<sub>2</sub>), Argon, Heliox (21 % O<sub>2</sub>, 79 %He), Oxygen/Nitrogen, Oxygen/Nitrous Oxide, Oxygen/Helium

Units of measure

- Flow ..... lpm (liter/minute), cfm (ft<sup>3</sup>/minute),  
lps (liter/sec), ml/min, ml/sec
- Pressure..... psi, kPa, bar, mbar, atm, inH<sub>2</sub>O (at  
4 °C), inHg (at 0 °C), cmH<sub>2</sub>O (at  
4 °C), mmHg (at 0 °C)
- Volume ..... l (liter), cf (ft<sup>3</sup>), ml
- Temperature ..... C, F
- Humidity ..... % RH

Safety

- General ..... IEC 61010-1: Pollution Degree 2
- Lithium Battery ..... IEC 62133

**Electromagnetic Compatibility (EMC)**

International .....IEC 61326-1: Controlled  
Electromagnetic Environment  
CISPR 11: Group 1, Class A

*Group 1: Equipment has intentionally generated and/or uses conductively-coupled radio frequency energy that is necessary for the internal function of the equipment itself.*

*Class A: Equipment is suitable for use in all establishments other than domestic and those directly connected to a low-voltage power supply network that supplies buildings used for domestic purposes. There may be potential difficulties in ensuring electromagnetic compatibility in other environments due to conducted and radiated disturbances.*

*Caution: This equipment is not intended for use in residential environments and may not provide adequate protection to radio reception in such environments.*

*Emissions that exceed the levels required by CISPR 11 can occur when the equipment is connected to a test object.*

Korea (KCC) .....Class A Equipment (Industrial  
Broadcasting & Communication  
Equipment)

*Class A: Equipment meets requirements for industrial electromagnetic wave equipment and the seller or user should take notice of it. This equipment is intended for use in business environments and not to be used in homes.*

USA (FCC).....47 CFR 15 subpart B. This product  
is considered an exempt device per  
clause 15.103.

Table 15. Breath Parameter Accuracy

| Parameter   | Abbreviation | Resolution  | Range                     | Accuracy                   |
|---|--------------|-------------|---------------------------|----------------------------|
| Inspiratory Tidal Volume  | Vti          | 0.1 ml      | 0 l to 60 l               | ±1.75 % of rdg or 0.005 l  |
| Expiratory Tidal Volume   | Vte          | 0.1 ml      | 0 l to 60 l               | ±1.75 % of rdg or 0.005 l  |
| Minute Volume<br>(The Expiratory Tidal Volume times the respiratory rate in breaths per minute. Reported as an eight-breath average.) | MV           | 0.001 lpm   | 0 l to 100 l              | ±1.75 % of rdg or 0.005 l  |
| Breath Rate   | BPM          | 0.1 bpm     | 1 bpm to 1500 bpm         | 1 %                        |
| Inspiratory to Expiratory Time Ratio (I:E Ratio)<br>(The ratio of the Inspiratory Time to the Expiratory Time)                        | I:E          | 0.01        | 1:300 to 300:1            | ±2 % or 0.1                |
| Peak Inspiratory Pressure<br>(The maximum pressure during the Inspiratory Time.)  | PIP          | 0.1 mbar    | ±160 mbar                 | ±0.75 % of rdg or 0.1 mbar |
| Inspiratory Pause Pressure  | IPP          | 0.1 mbar    | ±160 mbar                 | ±0.75 % of rdg or 0.1 mbar |
| Mean Airway Pressure<br>(The mean pressure over the entire breath.)   | MAP          | 0.1 mbar    | ±160 mbar                 | ±0.75 % of rdg or 0.1 mbar |
| Positive End-Expiratory Pressure<br>(The average pressure during the End Expiratory State.)   | PEEP         | 0.1 mbar    | ±160 mbar                 | ±0.75 % of rdg or 0.1 mbar |
| Lung Compliance <sup>(1)</sup>  | CMPL         | 0.1 ml/mbar | 0 ml/mbar to 1000 ml/mbar | ±3 % or 0.1 ml/mbar        |



**Table 15. Breath Parameter Accuracy (cont.)**

| Parameter   | Abbreviation | Resolution | Range           | Accuracy           |
|---|--------------|------------|-----------------|--------------------|
| Inspiratory Time<br>(The time of the inspiratory period including the inspiratory hold time.)                       | Ti           | 0.01 sec   | 0 sec to 60 sec | 0.02 sec           |
| Inspiratory Hold Time<br>(The time of the End Inspiratory State.)   | TiH          | 0.01 sec   | 0 sec to 60 sec | 1 % or 0.1 sec     |
| Expiratory Time<br>(The time of the expiratory period including the expiratory hold time.)                          | Te           | 0.01 sec   | 0 sec to 90 sec | 0.5 % or 0.01 sec  |
| Expiratory Hold Time<br>(The time of the End Expiratory State.)   | TeH          | 0.01 sec   | 0 sec to 90 sec | 0.02 sec           |
| Peak Inspiratory Flow<br>(The maximum of the absolute value of the Flow Rate measured during the Inspiratory Time.) | PIF          | 0.01 lpm   | ±300 lpm        | ±1.7 % or 0.04 lpm |
| Peak Expiratory Flow<br>(The maximum of the absolute value of the Flow Rate measured during the Expiratory Time.)   | PEF          | 0.01 lpm   | ±300 lpm        | ±1.7 % or 0.04 lpm |
| [1] Inspiratory pause time >0.5 sec   |              |            |                 |                    |

